

# Interfacing a Differential-Output (Isolated) Amplifier to a Single-Ended Input ADC



## Introduction

Whether you are sensing current in an industrial 3-phase servo motor system, a battery management system for an electric vehicle, or a photo voltaic inverter, it is often necessary to include some sort of safety isolation scheme. Safety-related standards define the specific isolation requirements for the end equipment associated with the particular design. Various factors come into play when determining what level of safety insulation (basic, supplemental, or reinforced) is required depending on the type of equipment, the voltage levels involved, and the environment that the equipment is to be installed.

Texas Instruments offers a variety of isolated current shunt amplifiers that are used in the previously-mentioned applications for voltage and current shunt sensing that meet either basic or reinforced insulation requirements. For applications requiring reinforced insulation, one such device is the AMC1301. The output of the AMC1301 is a fully differential signal centered around a common-mode voltage of 1.44 V that can be fed directly to a stand-alone analog-to-digital converter (ADC) as shown in Figure 1, or to the on-board ADC found in the MSP430 and C2000 family of micro-controller devices.

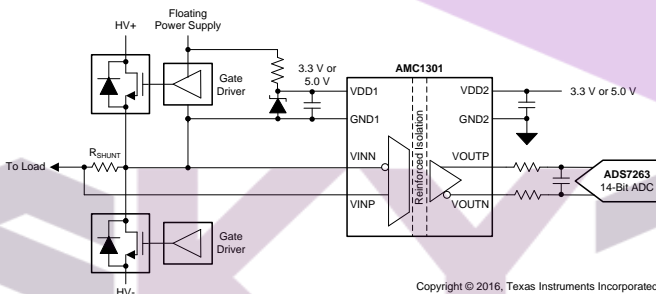

Figure 1. AMC1301 Functional Block Diagram

## Embedded ADCs

Both the MSP430 and C2000 family of processors have embedded single-ended input ADCs so the question becomes, “How do I get this differential signal into my single-ended data converter?”

The simplest way to achieve this is to use only one output of the AMC1301 leaving the second output floating. The down side to this solution is that only half the output voltage swing is available to the data converter, reducing the dynamic range of the

measurement. The analog input range to the AMC1301 is  $\pm 250$  mV. With a fixed gain of 8.2, the VOUTN and VOUTP voltages are  $\pm 1.025$  V centered around the 1.44-V common-mode output as shown in Figure 2. Differentially, the output voltage is  $\pm 2.05$  V.

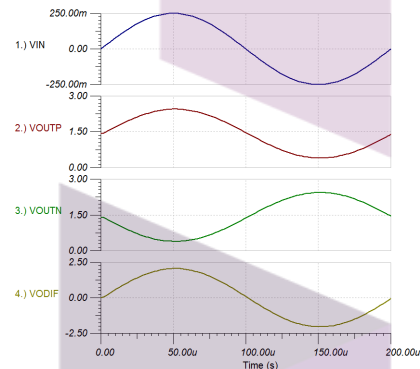

Figure 2. Differential Output Voltage

The addition of a differential to single-ended amplifier output stage, illustrated in Figure 3, allows the full output range of the AMC1301 to be provided to the ADC.

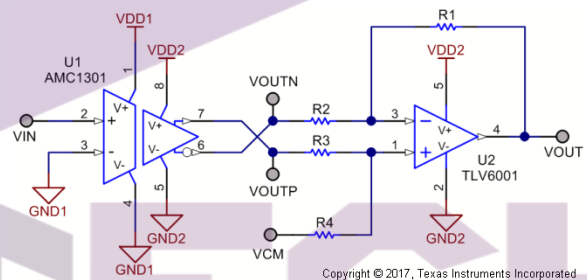

Figure 3. Differential to Single-Ended Output

Assuming a full scale sine wave of  $\pm 250$  mV is applied at VIN; the internal gain of the AMC1301 will provide 2.05 Vpk-pk outputs at points VOUTP and VOUTN which are 180° out of phase. The difference between these signals, VODIF, is 4.1 Vpk-pk. When  $R1 = R4$  and  $R2 = R3$  the transfer function of the output stage is shown in Equation 1.

$$VOUT = VOUTP \times \left(\frac{R4}{R3}\right) + VOUTN \times \left(\frac{R1}{R2}\right) + VCM \quad (1)$$

With equal value resistors for R1 through R4 in Equation 1 and VCM set to 2.5 V, Equation 1 reduces to:

$$V_{OUT} = (V_{OUTP} - V_{OUTN}) + V_{CM} \quad (2)$$

The plots of Figure 4 show the input voltage and output voltages of the AMC1301 along with the output voltage of the final differential to single-ended output stage. Note that the differential voltage of  $\pm 2.05$  V is transposed to a single-ended signal from 0.5 to 4.5 V.

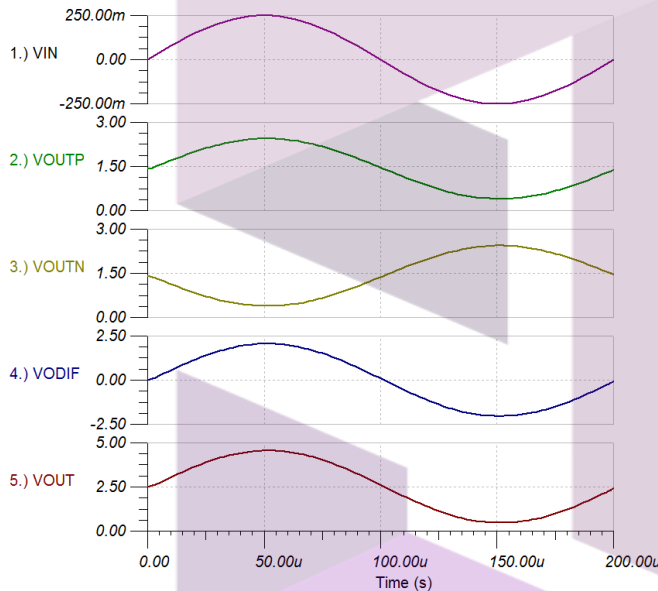

Figure 4. Single-Ended Output Voltage

Depending on the input voltage range of the ADC, gain or attenuation can be incorporated into the differential to single-ended stage to adjust the output swing. The output common mode voltage can be adjusted to fit the input needs of the ADC as well.

### Design Example

The ADC12 found on the MSP430 devices have an input voltage range of 0–2.5 V when using the internal voltage reference. Using the VOUTP from the AMC1301 would provide the ADC12 with an input signal ranging from 0.415 V to 2.465 V, well within the input range of the converter while only utilizing half the

input range of the AMC1301. As shown in Figure 5, utilizing a differential to single-ended amplifier configuration with a gain of 0.5 and common mode voltage of 1.25 V, the entire voltage range of the AMC1301 can be applied to the ADC12.

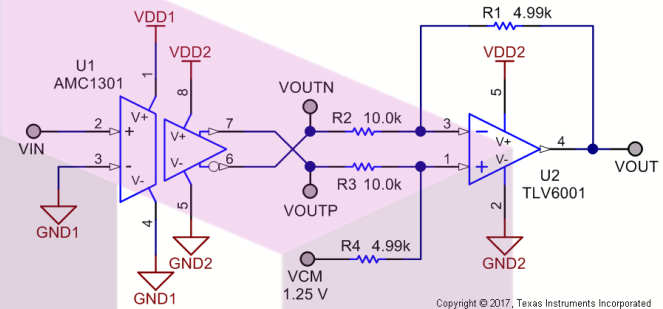

Figure 5. Scaled Differential to Single-Ended Output

### Alternative Device Recommendations

The AMC1100 or AMC1200 provide basic isolation with similar performance to the AMC1301 at a lower price point. For applications requiring a bipolar output option, the TLV170 is an excellent choice.

Table 1. Alternative Device Recommendations

Device	Optimized Parameter	Performance Trade-Off
AMC1100	Galvanic Isolation up to 4250 V <sub>PEAK</sub>	Lower Transient Immunity
AMC1200	Galvanic Isolation up to 4250 V <sub>PEAK</sub>	Basic Isolation versus Reinforced
TLV170	Bi-polar operation to $\pm 18$ V	Higher input bias current

### Conclusion

While it is possible to use a single output of the AMC1301 to drive a single-ended ADC, adding a differential to single-ended op-amp stage at the output ensures the target application will have the largest possible dynamic range.

Table 2. Related TI Tech Notes

SBOA161	Low-Drift, Low-Side Current Measurements for Three-Phase Systems
SBOA165	Precision Current Measurements on High Voltage Power Supply Rails

تهیه و توزیع قطعات الکترونیک

## IMPORTANT NOTICE FOR TI DESIGN INFORMATION AND RESOURCES

Texas Instruments Incorporated ("TI") technical, application or other design advice, services or information, including, but not limited to, reference designs and materials relating to evaluation modules, (collectively, "TI Resources") are intended to assist designers who are developing applications that incorporate TI products; by downloading, accessing or using any particular TI Resource in any way, you (individually or, if you are acting on behalf of a company, your company) agree to use it solely for this purpose and subject to the terms of this Notice.

TI's provision of TI Resources does not expand or otherwise alter TI's applicable published warranties or warranty disclaimers for TI products, and no additional obligations or liabilities arise from TI providing such TI Resources. TI reserves the right to make corrections, enhancements, improvements and other changes to its TI Resources.

You understand and agree that you remain responsible for using your independent analysis, evaluation and judgment in designing your applications and that you have full and exclusive responsibility to assure the safety of your applications and compliance of your applications (and of all TI products used in or for your applications) with all applicable regulations, laws and other applicable requirements. You represent that, with respect to your applications, you have all the necessary expertise to create and implement safeguards that (1) anticipate dangerous consequences of failures, (2) monitor failures and their consequences, and (3) lessen the likelihood of failures that might cause harm and take appropriate actions. You agree that prior to using or distributing any applications that include TI products, you will thoroughly test such applications and the functionality of such TI products as used in such applications. TI has not conducted any testing other than that specifically described in the published documentation for a particular TI Resource.

You are authorized to use, copy and modify any individual TI Resource only in connection with the development of applications that include the TI product(s) identified in such TI Resource. NO OTHER LICENSE, EXPRESS OR IMPLIED, BY ESTOPPEL OR OTHERWISE TO ANY OTHER TI INTELLECTUAL PROPERTY RIGHT, AND NO LICENSE TO ANY TECHNOLOGY OR INTELLECTUAL PROPERTY RIGHT OF TI OR ANY THIRD PARTY IS GRANTED HEREIN, including but not limited to any patent right, copyright, mask work right, or other intellectual property right relating to any combination, machine, or process in which TI products or services are used. Information regarding or referencing third-party products or services does not constitute a license to use such products or services, or a warranty or endorsement thereof. Use of TI Resources may require a license from a third party under the patents or other intellectual property of the third party, or a license from TI under the patents or other intellectual property of TI.

TI RESOURCES ARE PROVIDED "AS IS" AND WITH ALL FAULTS. TI DISCLAIMS ALL OTHER WARRANTIES OR REPRESENTATIONS, EXPRESS OR IMPLIED, REGARDING TI RESOURCES OR USE THEREOF, INCLUDING BUT NOT LIMITED TO ACCURACY OR COMPLETENESS, TITLE, ANY EPIDEMIC FAILURE WARRANTY AND ANY IMPLIED WARRANTIES OF MERCHANTABILITY, FITNESS FOR A PARTICULAR PURPOSE, AND NON-INFRINGEMENT OF ANY THIRD PARTY INTELLECTUAL PROPERTY RIGHTS.

TI SHALL NOT BE LIABLE FOR AND SHALL NOT DEFEND OR INDEMNIFY YOU AGAINST ANY CLAIM, INCLUDING BUT NOT LIMITED TO ANY INFRINGEMENT CLAIM THAT RELATES TO OR IS BASED ON ANY COMBINATION OF PRODUCTS EVEN IF DESCRIBED IN TI RESOURCES OR OTHERWISE. IN NO EVENT SHALL TI BE LIABLE FOR ANY ACTUAL, DIRECT, SPECIAL, COLLATERAL, INDIRECT, PUNITIVE, INCIDENTAL, CONSEQUENTIAL OR EXEMPLARY DAMAGES IN CONNECTION WITH OR ARISING OUT OF TI RESOURCES OR USE THEREOF, AND REGARDLESS OF WHETHER TI HAS BEEN ADVISED OF THE POSSIBILITY OF SUCH DAMAGES.

You agree to fully indemnify TI and its representatives against any damages, costs, losses, and/or liabilities arising out of your non-compliance with the terms and provisions of this Notice.

This Notice applies to TI Resources. Additional terms apply to the use and purchase of certain types of materials, TI products and services. These include; without limitation, TI's standard terms for semiconductor products (<http://www.ti.com/sc/docs/stdterms.htm>), [evaluation modules](#), and [samples](http://www.ti.com/sc/docs/sampterm.htm) (<http://www.ti.com/sc/docs/sampterm.htm>).

Mailing Address: Texas Instruments, Post Office Box 655303, Dallas, Texas 75265  
Copyright © 2017, Texas Instruments Incorporated

# SKYTECH

# تهیه و توزیع قطعات الکترونیک